

memory mapped I/O using external data memory

0x0000	lcd command write
0x0001	lcd data write
0x0002	lcd command read
0x0003	lcd data read
0x0100	GPIO1
0x0200	GPIO2
0x0300	expansion i/o space
0x07FF	

Designed by Wicht Sirichote, kswichit@kmitl.ac.th

Title		
8051SBC V1.1		
Size	Document Number	Rev
B	<Doc>	1
Date:	Saturday, June 25, 2005	Sheet 1 of 2

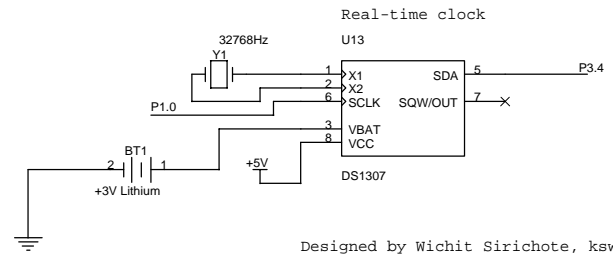
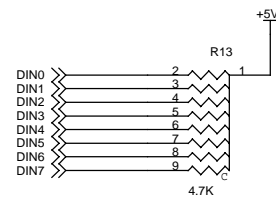
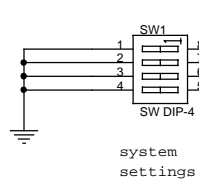
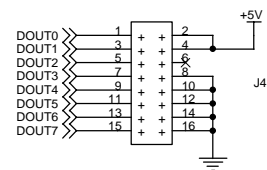
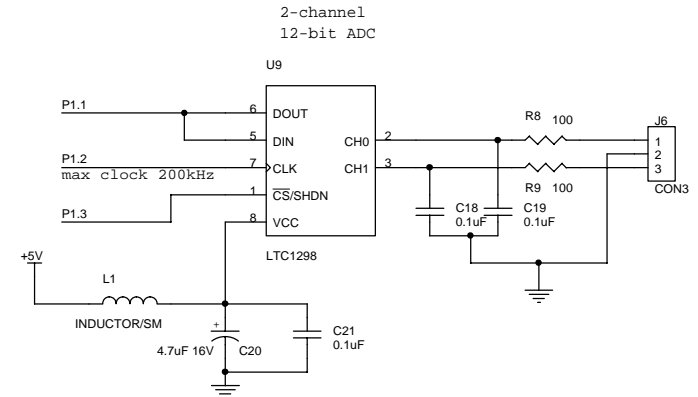
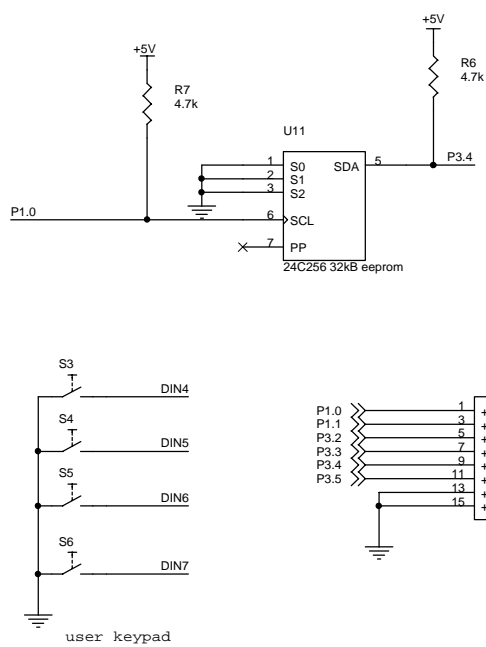
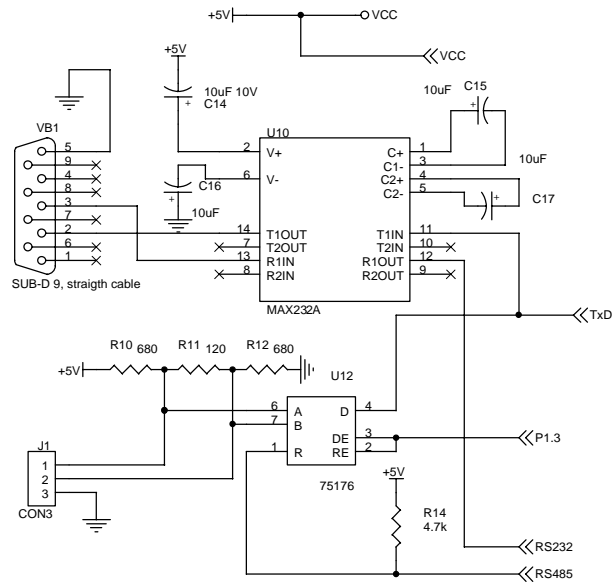
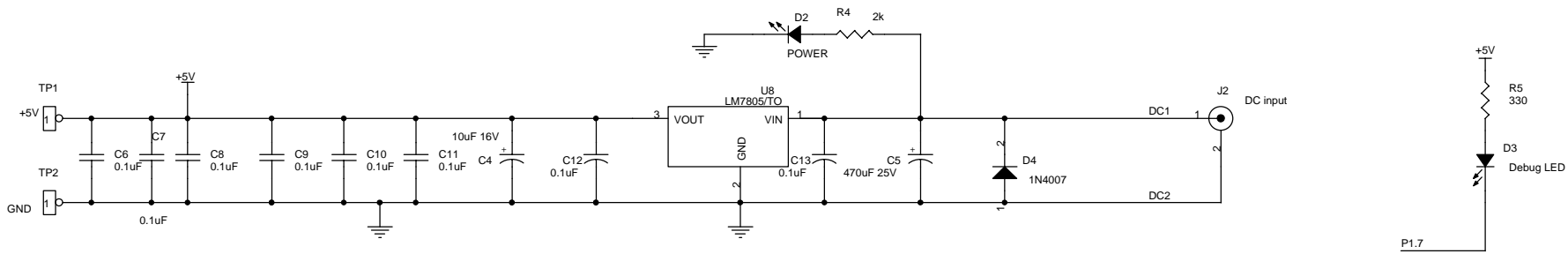

Designed by Wichit Sirichote, kswichit@kmitl.ac.th

Title		
8051SBC V1.1		
Size	Document Number	Rev
B	<Doc>	2
Date:	Saturday, June 25, 2005	Sheet 2 of 2