

Directional Filtered Fingerprint Images: An Investigation and Evaluation of Minutiae Consistency

Keokanlaya Sihalath ^{*1}, Somsak Choomchuay ^{*2}, and Kazuhiko Hamamoto ^{**}

^{*} Department of Electronic Engineering, Faculty of Engineering, King Mongkut's Institute of Technology Ladkrabang
Chalongkrung Road, Ladkrabang, Bangkok 10520, Thailand

^{*1} e-mail: keokanlaya@gmail.com ^{*2} email: skcxch@gmail.com;

^{**} Information Media Technology, School of Information Technology and Electronics
Tokai University, Tokyo, Japan
e-mail: hama@keyeki.cc.u-tokai.ac

Abstract—In this paper, we investigate the consistency of minutiae that could be effected by the application of directional filtering during the fingerprint image enhancement process. Two types of similar filters: Gabor filter and Second derivative of Gaussian filters are employed for investigation. These filters are also used in the scheme of directional wavelet transform and pyramid technique. The commonly-well-known database FVC-2004 is used in this study. Based on the obtained results we can conclude that ridge end point and bifurcation is influenced by the filtering application. Moreover, the condition of the input image is also very important for the designed filter to work efficiently.

Keywords- *Fingerprint enhancement; Minutiae; Directional filtering; Biometric*

I. INTRODUCTION

Among the uses of biometric in personal identification, fingerprint-base identification has been used for a very long time. A fingerprint is the pattern of ridges and valleys on the surface of a finger. Minutiae are local discontinuities in the fingerprint pattern. The most important ones are ridge ending and ridge bifurcation. Spurious ridge structure may change the individuality of input fingerprints. The core point as well as the delta point(s) that are always known as singular points have played important roles in many fingerprints identify techniques [1, 2, 3]. Not less, minutiae-based fingerprint matching is also widely used [4, 5]. The correct detection of endpoint (ridge-ending), junction (ridge-bifurcation), core point and delta point is therefore very important. This is very much relied on the image quality. In many cases, fingerprint with numerous discontinuous ridges (dry, wet, damped, scars and smudges) can cause errors in fingerprint identification process. Noise and contrast deficiency can produce false minutiae or hide valid ones. Even high quality images can also yield false minutiae, for example, when the person has cuts or scars in his/her fingers.

The main objective of an enhancement process is to improve the clarity of ridge structures of fingerprint images in recoverable regions and to remove the

unrecoverable regions. Fingerprint enhancement can be applied to either a gray-level fingerprint image [6] or a binary one [7]. As ridges and valleys in a fingerprint image alternate and run parallel to each other in a local neighborhood. Ridges and valleys in a local neighborhood form a sinusoidal-shaped plane wave, which has a well-defined frequency and orientation. These specific features of a fingerprint image have led to several image filtering and enhancement techniques.

Of with the ridge direction and ridge frequency of the fingerprint image, there appear many algorithms and techniques proposed for image enhancement. These are, for instance, using Fourier Transforms [8, 9], Gabor filters [4, 10], Wavelet transform [11, 12, 13]. On the positive side, the filter tries to remove noise, enhance the ridge contrast, and try to repair the broken ridge. On the negative side, the filter wrongly joined the too-close ridge. This can produce the wrong bifurcation. If those broken ridges cannot be joined, the unnecessary line-ends are detected. Minutiae-base matching is then fail or the matching score is lower.

In this paper, we investigate the effect of directional filter applied in fingerprint image enhancement. We would like to know whether the minutiae (such as ridge end and bifurcate) could be enhanced or reversely be destroyed. The rest of this paper is organized as follows: In section II, we outline the enhancement process that includes; normalization, directional field estimation and smoothing, directional filtering, and thinning for minutiae detection. In section III, directional filters are elaborated in quite detail. Directional wavelet transform and pyramid technique are also included. Experiment and results are given in section IV. In this section, ridge end and bifurcation are observed separately. Finally we concluded the paper in section V.

II. ENHANCEMENT PROCESS

A. Normalization

This step is quite common in many image processing routines. The effort can reduce the variance in gray-level values along ridges and valleys by means of adjusting the gray-level values to the predefined constant mean and variance. And normalization can remove the influences of sensor noise and gray-level deformation.

This work is partially supported by AUN/SEED-Net program under the Research Collaboration scheme.

B. Frequency Estimation & Field Estimation

We can approximate ridge frequency of the fingerprint image by dividing it into blocks (for instance, pixels). For any local neighborhood which does not have singularities (core or delta), the gray-levels of the pixels form a sinusoidal shape along the direction orthogonal to the ridge orientation. An oriented window (oriented in the direction orthogonal to the local ridge orientation) is used to approximate this sinusoid. The inverse of the average distance between the numbers of peaks encountered is the local frequency of that block. In our case, the ridge frequency of 0.10-0.12 was measured. The obtained frequency is used in the directional filtering step.

Since directional filtering is a direction-sensitive filter. We have to estimate the local orientation before applying the filter. Before such an attempt we apply 2D Low Pass Wiener filter (block of 5×5) to the image as a purpose of noise reduction with some effect of directional filtering.

Let $\phi(i, j)$ be the *orientation field* that represents the local ridge at pixel (i, j) . The local ridge is generally specified for a block rather than for every pixel. Thus, an image is divided in to a set of non-overlapping blocks, size of $w \times w$. Each bock holds a single orientation. A procedure proposed for orientation estimation is summarized below [4].

Divide the input image into consecutive (non-overlapping) blocks size of $w \times w$. We used $w = 15$.

Compute the x and y magnitude of the gradients $\partial_x(u, v)$ and $\partial_y(u, v)$, at each pixel (i, j) .

The local orientation of each block centered at pixel (i, j) can be estimated by:

$$\phi(i, j) = \frac{1}{2} \tan^{-1} \left(\frac{V_y(i, j)}{V_x(i, j)} \right) \quad (1)$$

Where, $\phi(i, j)$ is the least square estimate of the local ridge orientation of the block centered at pixel (i, j) and

$$V_x(i, j) = \sum_{u=i-w/2}^{i+w/2} \sum_{v=j-w/2}^{j+w/2} 2\partial_x(u, v)\partial_y(u, v), \quad (2)$$

$$V_y(i, j) = \sum_{u=i-w/2}^{i+w/2} \sum_{v=j-w/2}^{j+w/2} 2\partial_x^2(u, v)\partial_y^2(u, v), \quad (3)$$

Given in eqn. (1) is just the estimation of orientation field. For some fine applications and an application that involve no directional filter, one can perform field smoothing. The operation requires conversing the current estimated field into continuous vector field that followed by a low pass filtering. In this paper, however, field smoothing is omitted.

C. Directional Filtering (DF)

Based on the estimated field, the directional filter is applied. The gray scale image is enhanced eventually.

Two similar filters will be given in more details in the next section. The said filters are extended to corporate with wavelet and pyramid technique.

D. Thinning and Minutiae Allocation

For the enhanced image to be investigated for its minutiae location consistency, the ridges are thinned such that the pattern line width is only a single pixel. Ridge end and bifurcation are then easily located. In contrast, this step in no need for core and/or delta point detection. A well recognized technique such as Poincare is used instead.

III. DIRECTIONAL FILTERING

Directional filtering is of interest when one wants to highlight the image pattern or texture holding particular direction or orientation. Gabor filter is a linear filter used in image processing. Its impulse response is defined by a harmonic function multiplied by a Gaussian function. Similarly, second derivative of Gaussian function modified by multiplying with a cosine function can hold the feature of direction filtering.

A. Gabor Filter

The Gabor filter have both frequency-selective and orientation-selective properties and have optimal joint resolution in both spatial and frequency domains.

$$h(x, y : \phi, f) = \exp \left[-\frac{1}{2} \left(\frac{x_\phi^2 + y_\phi^2}{\sigma_x^2 + \sigma_y^2} \right) \right] \cos(2\pi f x_\phi) \quad (4)$$

where

$$x_\phi = x \cos \phi + y \sin \phi \quad (5)$$

$$y_\phi = -x \sin \phi + y \cos \phi \quad (6)$$

Where, ϕ is the orientation of the Gabor filter, f is the frequency of a sinusoidal plane wave, σ_x and σ_y are the standard deviations of the Gaussian envelope along x and y axes, respectively.

B. Second Derivative Gaussian Filter (SDGF)

This second derivative can enhance the ridge and suppress the valley for certain degree. To enhance the effectiveness of the filter we can modify equation (15) slightly by co-operating the cosine function (or plan wave) as follow [14]:

$$sdg(x, y : \phi, f) = \frac{(x_\phi^2 - \sigma_\phi^2)(y_\phi^2 - \sigma_\phi^2)}{2\pi\sigma_\phi^{10}} \exp \left(-\frac{x_\phi^2 + y_\phi^2}{\sigma_\phi^2} \right) \cos(2\pi f x_\phi) \quad (7)$$

Where, ϕ is the orientation of the second derivative filter, f is the frequency of a sinusoidal plane wave, σ_ϕ is the standard deviations of the Gaussian envelope. x_ϕ and y_ϕ define the x and y axes of the filter coordinate frame.

Appearance of Gabor filter and second derivative filter is shown in Fig. 1 below. They are actually in the same class [15].

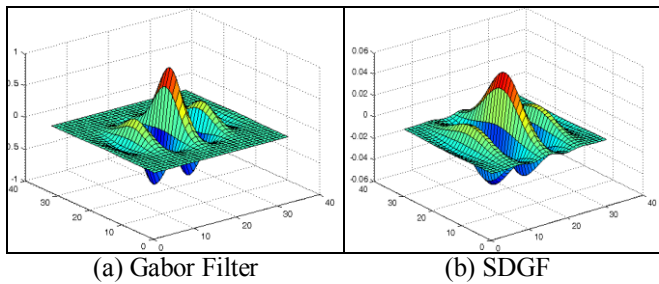

(a) Gabor Filter (b) SDGF

Figure 1. Appearance of filters

(Gabor filter: $\sigma_x = 0.4, \sigma_y = 0.5, \phi = 0^\circ, f = 0.12$)

(SDGF: $\delta_\phi = 0.4, \phi = 0^\circ, f = 0.12$)

C. Directional Wavelet Transform

The discrete wavelet transform of function $f(x,y)$ of size $M \times N$ is formulated as:

$$W_\phi(j_0, m, n) = \frac{1}{\sqrt{MN}} \sum_{x=0}^{M-1} \sum_{y=0}^{N-1} f(x,y) \phi_{j_0, m, n}(x,y) \quad (8)$$

$$W_\psi^i(j, m, n) = \frac{1}{\sqrt{MN}} \sum_{x=0}^{M-1} \sum_{y=0}^{N-1} f(x,y) \psi_{j, m, n}^i(x,y) \quad (9)$$

where $i = \{H, V, D\}$, $\psi^i(x,y)$ are directional wavelet, j_0 is the starting scale of a scaling function $\phi(x,y)$, and the $W_\phi(j_0, m, n)$ coefficients define the approximation of $f(x,y)$, at scale j_0 . The $W_\psi(j, m, n)$ coefficients represent the horizontal, vertical and diagonal details for scales $j \geq j_0$. Here $j_0 = 0$ and select $M + N = 2^J$ so that $j = 0, 1, 2, \dots, J-1$ and $m, n = 0, 1, 2, \dots, (2^j - 1)$. Then $f(x,y)$ is obtained via the inverse discrete wavelet transform.

$$f(x,y) = \frac{1}{\sqrt{MN}} \sum_m \sum_n W_\phi(j_0, m, n) \phi_{j_0, m, n}(x,y) + \frac{1}{\sqrt{MN}} \sum_{i=H,V,D} \sum_{j=j_0}^{\infty} \sum_m \sum_n W_\psi^i(j, m, n) \psi_{j, m, n}^i(x,y), \quad (10)$$

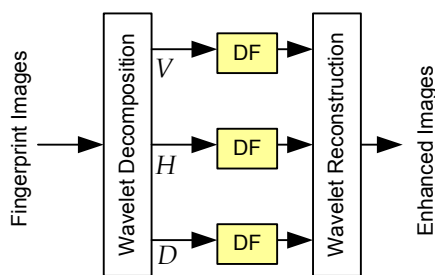

Figure 2. Fingerprint enhancement by mean of wavelet transform and directional filtering

In this work, a directional wavelet transform is applied to decompose the image into its orientation representation [16]. Directional filtering is applied to each direction before image reconstruction. This is shown in Fig. 2 below. We have applied the Gabor filter and the second derivative of Gaussian filter in the DF state.

D. Pyramid Technique

As a multi-resolution processing, the image pyramid has been applied for fingerprint enhancement lately [15, 17]. The Gaussian pyramid decomposes the image into several bands. It acts as a low pass filter. In contrast, the Laplacian pyramid is actually equivalent to band pass filtering in the spatial domain.

Shown in Fig. 2 below, in the decomposition phase the image is down sampled by half at each level. 3-4 levels are generally sufficient for most applications. At each level, a directional filter is applied and the image $L_i(m_i, n_i)$ is obtained. There is no need to apply the filter to the final state (last level).

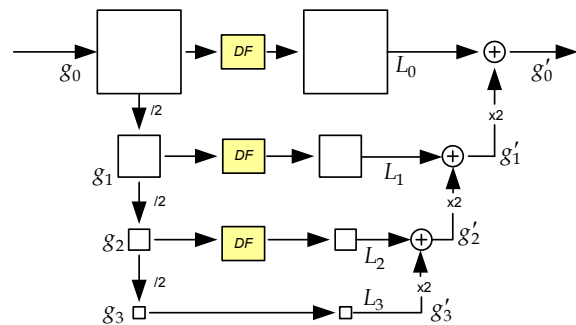

Figure 3. Pyramid technique in fingerprint image enhancement

In the construction phase, the stored image is up sampled by the factor of 2 and added to the lower level image of which the same dimension. The said operation is applied successively until the original dimension is reached and the enhanced image is obtained.

IV. EXPERIMENT & RESULTS

We used the downloaded DB1_A of FVC-2004 as our database in this study [18]. Captured with optical sensor, "V300" by CrossMatch, an image size is of 640×480 pixels with 500 dpi resolutions. In our experiment we randomly chose 6 fingerprint images; all are quite varied in image quality. However, all holds core point. Orientation field estimation is applied after image normalization. Two type of directional filters; namely Gabor filter and Second derivative of Gaussian filter are investigated together with other two arrangements which are directional wavelet transform technique and pyramid technique. The filtered image is then thinned for the ease of ridge end and bifurcation observation. The obtained results are given in Table I and Table II. Table I demonstrates the ridge end points whilst table II demonstrates the bifurcation. Shown in Fig. 4 are the example images of various process steps.

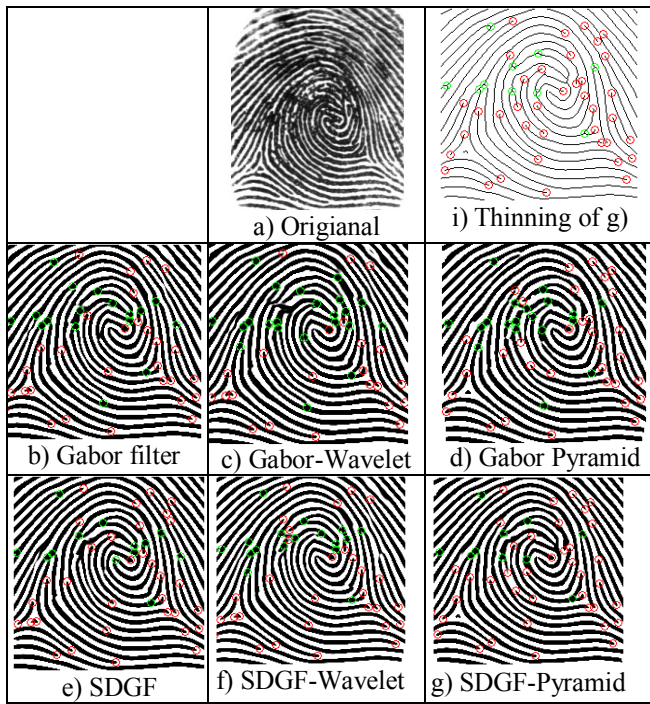

Figure 4. Images at various process step

Shown in Table I and II, our counting is based on the genuine point. The positive or negative value means how big the difference the number of points it holds compare with the number of genuine points. It is quite clear that corporation of the filter with either wavelet transform or pyramid technique can offer better performance as the number of ridge end point decreases when compared to that of applying the filter only. However, one also can notice that the filter application can destroy the genuine end point. Such a situation is demonstrated by the negative difference. This can happen because the too-close ridges are joined. According to Table I, Image #2 is greatly influenced by the said conditions.

Application of the filter for image enhancement seems to have less effect on bifurcation. In many cases, the destroyed line-ends are because of their joining and a bifurcation is generated. If one looks into Table II, the said conditions are revealed. Image #2 (see also Fig. 6) holds some thicker line near its end point the space between the considering line and the neighboring line is then lower. According to the field smoothing, those line are joined and a bifurcation is generated.

TABLE I. RIDGE END DETECTION

	Images					
	#1	#2	#3	#4	#5	#6
Genuine Ridge End	13	9	5	13	23	8
Gabor Filter	+1	0	-1	+1	+1	0
Gabor-Wavelet	0	-1	0	-1	+1	-1
Gabor-Pyramid	-1	-1	+1	+1	0	+1
SDGF	+1	-1	+1	+1	0	0
SDGF-Wavelet	-1	-2	+1	+1	+1	0
SDGF-Pyramid	-1	-1	0	+1	+1	+1

TABLE II. BIFURCATION DETECTION

	Images					
	#1	#2	#3	#4	#5	#6
Genuine Bifurcate	8	13	13	16	13	16
Gabor Filter	0	-1	0	-1	+1	0
Gabor-Wavelet	+1	0	0	0	-1	0
Gabor-Pyramid	+1	0	-1	0	-1	0
SDGF	-1	0	0	0	0	0
SDGF-Wavelet	0	+2	0	-1	0	0
SDGF-Pyramid	0	0	0	-1	-1	0

SDGF=Second Derivative of Gaussian Filter

Shown in Fig. 5, we have circled some obvious incomplete filtering that result in wrong ridge end decision. In the upper and left circles, an island (should contain 2 ridge ends) is marked as 1 ridge end and 1 bifurcate. For the middle circle, the situation is more complicate. Perhaps without eye-observe made to the actual pattern it is fairly hard to identify the ride end and bifurcation.

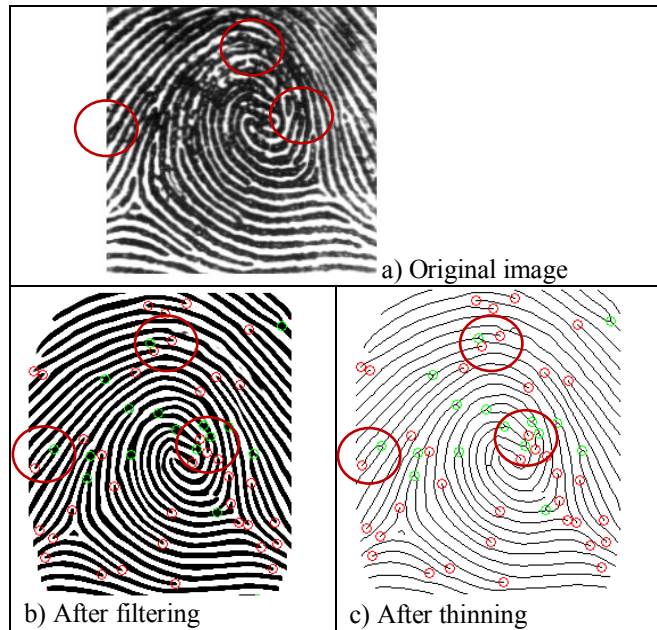

Figure 5. Some imperfect filterings than can cause wrong decision

CONCLUSIONS

In this paper we have studied the consistency of minutiae of fingerprint images enhanced by the use of directional filtering. Two similar filters: Gabor filter and second derivative of Gaussian filter are investigated. The corporation of these two filters in Directional wavelet arrangement and pyramid technique enhancement are also involved. Despite the computation complexity, the extra arrangement of the filter can perform the broken line connection. However, another obvious disadvantage is that: it does wrong join the too-close ridge. As a result, it sometimes produces some fake bifurcations. For a poor quality image and even an expert do the examination, it is

really difficult to justify for the interest feature. In many cases, the broken lines still cannot be joined by the filter. The fake ridge ends still exist. The window size used during the field estimation process is also important in such a way that; on one side too big window can give the good field smoothing but it can ignore the bifurcation. On the other side the too small window size cannot join well the broken ridge but it pick up well those bifurcations. We conclude our observation that designing of the filter is fairly critical. Its performance can be good for some type of poor images but may not so efficient for others. In most cases directional filter can remove noise dramatically.

ACKNOWLEDGMENT

This work is partially supported by AUN/SEED-Net Program. Authors would like to express our gratitude and sincere thanks to SEED-Net project.

REFERENCES

- [1] A.K. Jain S. Prabhakar L. Hong and S. Pankanti, "Filterbank-Based Fingerprint Matching," *IEEE Trans. Image Processing*, vol. 9, no. 5, pp. 846-859, 2000.
- [2] A. Julasayvake and S. Choomchuay, "An Algorithm for Fingerprint Core Point detection," *Proc. of Int. Symp. on Signal Processing and its Applications 2007 (ISSPA-2007)*, United Arab Emirates, February 2007.
- [3] Sen Wang and Yangsheng Wang, "Fingerprint Enhancement in the Singular Point Area," *IEEE signal processing letters*, vol. 11, no. 1, pp. 16-19, January 2004.
- [4] L. Hong, Y. Wan, and A. Jain. "Fingerprint image enhancement: Algorithm and performance evaluation," *IEEE Transactions on Pattern Analysis and Machine Intelligence*, 20(8):777-789, August 1998.
- [5] Y. He, J. Tang, X. Luo, and T. Zhang, "Image enhancement and minutiae matching in fingerprint verification," *Pattern Recognition Letters*, 24, 2003.
- [6] D. Maio, D. Maltoni, "Direct Gray-Scale Minutiae Detection in Fingerprints," *IEEE Trans. Pattern Anal. Machine Intell.*, Vol. 19, No. 1, pp. 27-40, 1997.
- [7] A. Farina, Z.M. Kovacs-Vajna, and A. Leone, "Fingerprint minutiae extraction from skeletonized binary images," *Pattern Recognition*, 32(5):877-889, 1999.
- [8] B. G. Sherlock, D. M. Monro, and K. Millard. "Fingerprint enhancement by directional Fourier Filtering," *IEEE Proceedings in Visual Image Signal Processing*, 141(2):87- 94, April 1994.
- [9] S. Chikkerur and V. Govindaraju, "Fingerprint image enhancement using STFT analysis," in *Proc. Int. Workshop on Pattern Recognition for Crime Prevention, Security and Surveillance*, 2005, pp. 20-29.
- [10] J. Yang, L. Liu, T. Jiang, and Y. Fan, "A modified gabor filter design method for fingerprint image enhancement". *Pattern Recognition Letters*, 24:1805-1817, 2003.
- [11] Zhengmao Ye, Habib Mohamadian, and Yongmao Ye, "Information Measures for Biometric Identification via 2D Discrete Wavelet Transform," *Proceedings of the 3rd Annual IEEE Conference on Automation Science and Engineering Scottsdale, AZ, USA, Sept 22-25, 2007*.
- [12] Anto Melvin Paul and R. Mary Lourde, "A Study on Image Enhancement Techniques for Fingerprint Identification" . *Proceedings of the IEEE International Conference on Video and Signal Based Surveillance - AVSS'06*.
- [13] Wei-Peng, Zhang, Qing-Ren. Wang, Y. Tang, "A wavelet-based method for fingerprint image enhancement". *Proceeding of the First International Conference on Machine Learning and Cybernetics, Beijing, 4-5 November 2002*
- [14] F. Yue, W.Zuo, K.Wang, and D. Zhang, "A Performance Evaluation of Filter Design and Coding Schemes for Palmprint Recognition," *Proc. of ICPR 2008*.
- [15] S. Choomchuay and K. Sihalath, "An Application of Second Derivative of Gaussian Filters in Fingerprint Image Enhancement," *Proc. of iCBBE-2010*.
- [16] K. Sihalath, S. Choomchuay, S. Wada, and K. Hamamoto, "Fingerprint Image Enhancement with Second Derivative Gaussian Filter and Directional Wavelet Transform," *Proc. of ICTTA-2010*.
- [17] H. Fronthaler, K. Kollreider, and J. Bigun, "Local Features for Enhancement and Minutiae Extraction in Fingerprints," *IEEE Trans. on Imag. Proc.* Vol.17, No.3, March 2008, pp. 354-363.
- [18] Finger print Verification Contest 2002; FVC2002: Available at <http://bias.csr.unibo.it/fvc2002/>

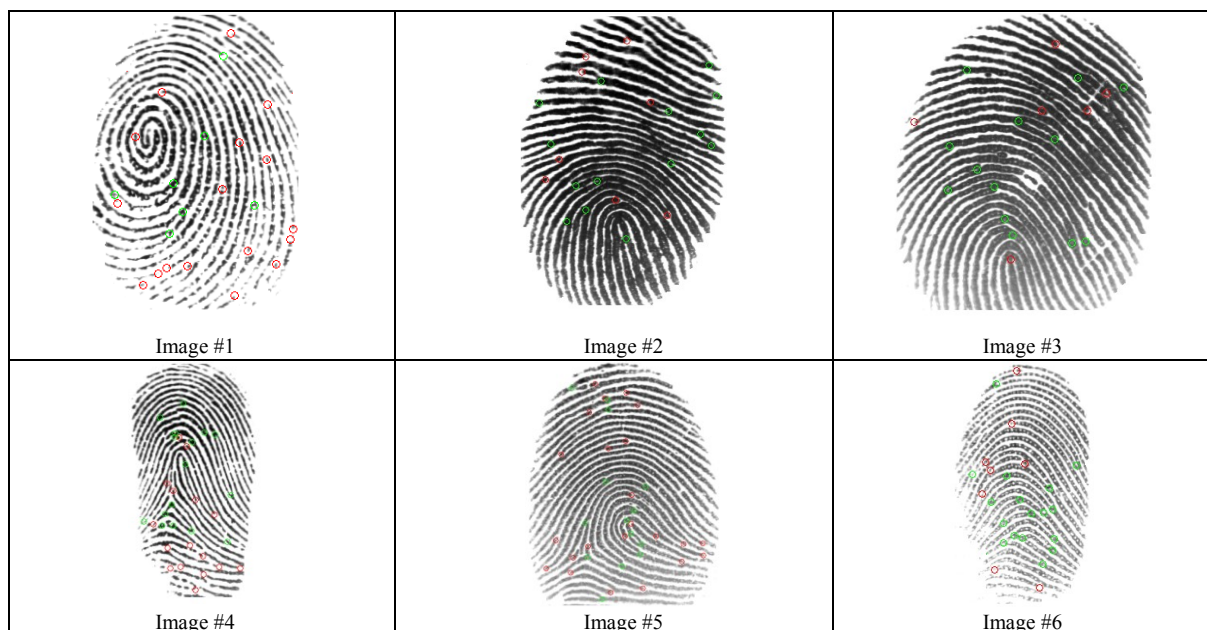

Figure 6. Original Images Referred in our Experiment